



**PRODUCT DATA SHEET**

P/N: **1027**  
**LOOP HOOK**



The Loop Hook is a unique and efficient way to mount or hang equipment that utilize locking straps.

**TYPICAL SPECIFICATION**

Mounting Bracket shall be PAC PN 1027.

Bracket shall be single piece construction; made from tough, corrosion free material. Hardware shall be stainless steel.

Firefighters shall be protected from conductivity.

**FEATURES**

- Strong and versatile
- Molded from high strength material
- Impact resistant
- Multiple uses
- Stainless Steel Fasteners provided
- Mounts to PAC tool boards flat surfaces
- Available in Black or Green base colors

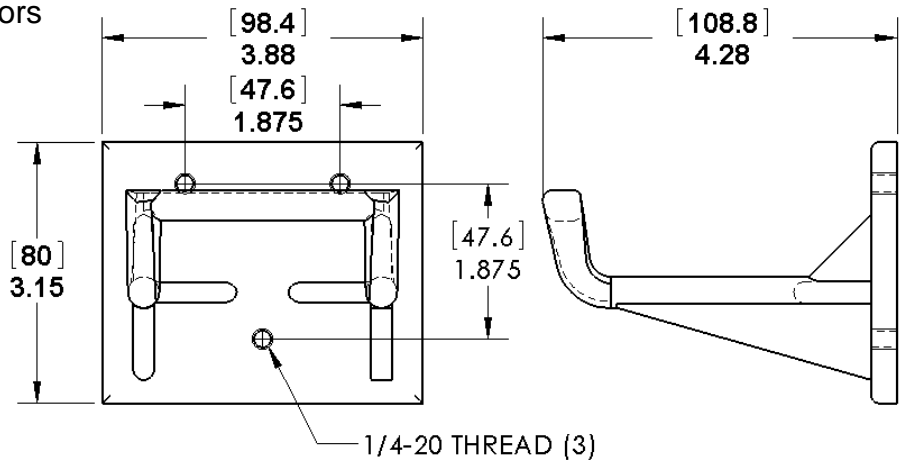

**SPECIFICATIONS**

P/N	WT.	MAX LOAD	GRIP RANGE	HANGER RANGE	FLAME TOXICITY CHEMICAL
1027	.3lbs	N/A	N/A	Width up to 3.5"	N/A

Performance Advantage Company

Lancaster, New York

www.pactoolmounts.com

888-514-0083

REFERENCE	QTY	REMARKS	PROJECT
			LOCATION
			BUYER
			DEALER
			BUILDER
			SUBMITTED BY:
			DATE:



**The Loop Hook is a unique and efficient way to mount or hang equipment that utilize locking straps.**

- Strong and versatile
  - Multiple uses
  - Stainless Steel Fasteners provided
  - Mounts to PAC tool boards flat surfaces
  - Available in Black or Green base colors
-